

## APPLICATION NOTE

### MPQ1000 Common Connections

#### 2 Wire Single Phase Single Wattmeter

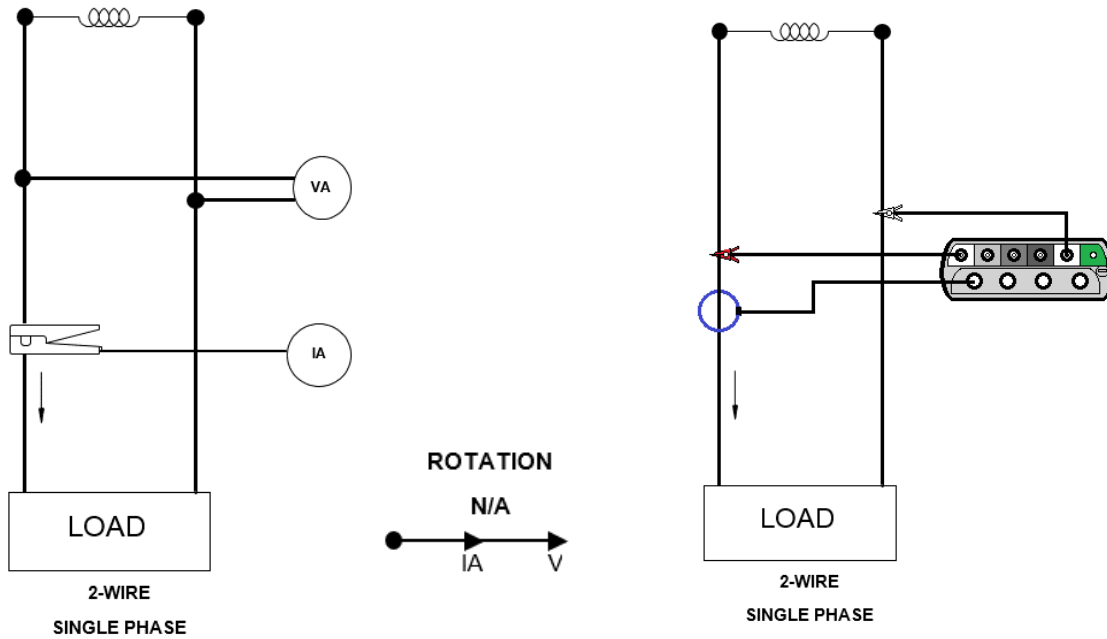

#### Single Wattmeter – (1 Voltage and 1 Current)

When connected the phase rotation of the current must be within +/- 90 degrees of the voltage. If the phase rotation is greater than 90 degrees this will indicate that either the CT or the voltage connections are backwards.

The red arrow represents the voltage. The current arrow will need to be within the yellow range, shown in the image.

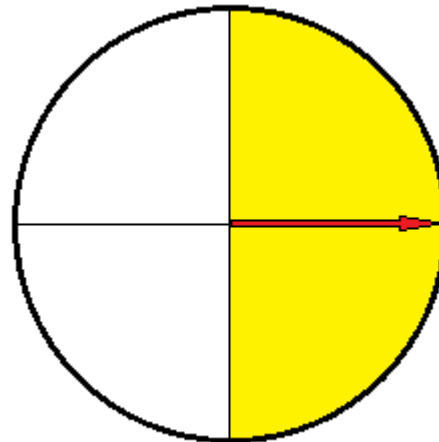

# APPLICATION NOTE

## MPQ1000 Common Connections

Megger PQ PC Software configuration

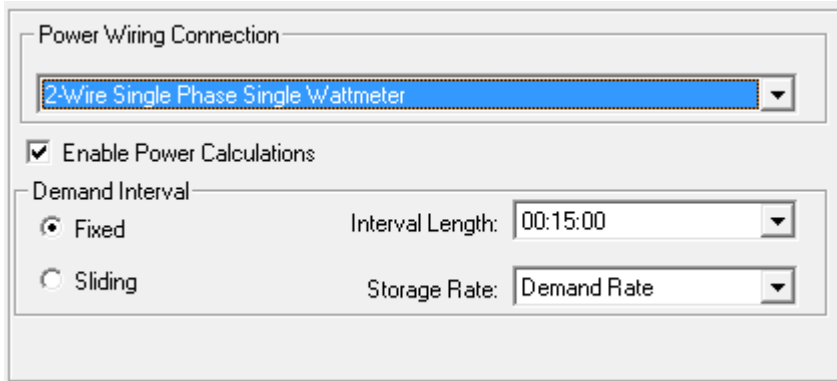

Megger PQ PC software “2 Wire Single Phase Single Wattmeter” configuration needs to be used with this type of connection.

Label	Channel	Sag Limit	Swell Limit	SubCycle Limit	Ratio	CT Full Scale	Nom Angle	Angle Dev +/-	RVC Thresh (%)	RVC Hysteresis (%)	Fast Transient (Volts)	THD Limit %
<input checked="" type="checkbox"/> Va	V1	<input type="checkbox"/> 114.000	<input type="checkbox"/> 126.000	120.0	1.000				3.00	10.00	<input type="checkbox"/> 126.000	<input type="checkbox"/> 7.00000
<input checked="" type="checkbox"/> Ia	I1	<input type="checkbox"/> 0.00000	<input type="checkbox"/> 300.000	300.0	1.000	6000.00	0.00					<input type="checkbox"/> 20.0000
<input type="checkbox"/> Vb	V2	<input type="checkbox"/> 114.000	<input type="checkbox"/> 126.000	120.0	1.000				3.00	10.00	<input type="checkbox"/> 126.000	<input type="checkbox"/> 7.00000
<input type="checkbox"/> Ib	I2	<input type="checkbox"/> 0.00000	<input type="checkbox"/> 300.000	300.0	1.000	6000.00						<input type="checkbox"/> 20.0000
<input type="checkbox"/> Vc	V3	<input type="checkbox"/> 114.000	<input type="checkbox"/> 126.000	120.0	1.000				3.00	10.00	<input type="checkbox"/> 126.000	<input type="checkbox"/> 7.00000
<input type="checkbox"/> Ic	I3	<input type="checkbox"/> 0.00000	<input type="checkbox"/> 300.000	300.0	1.000	6000.00						<input type="checkbox"/> 20.0000
<input type="checkbox"/> Vn	V4	<input type="checkbox"/> 114.000	<input type="checkbox"/> 5.00000	12.00	1.000				3.00	10.00		<input type="checkbox"/> 7.00000
<input type="checkbox"/> In	I4	<input type="checkbox"/> 0.00000	<input type="checkbox"/> 300.000	300.0	1.000	6000.00						<input type="checkbox"/> 20.0000

This configuration will automatically enable channel V1 “Va” and channel I1 “Ia”, since these channels are required for the power calculation.

Other channels can be enabled and connected to different nodes. This will not affect the power measurements.

Channel labels in the “Label” column can be changed to meet user needs. Up to 4 characters can be used.

The 2 Wire Single Phase Single Wattmeter configuration utilized line voltage (Phase – Neutral) and line current. When demand data (Power and Energy) is recorded both individual channel power and total power data will be valid and available.

## APPLICATION NOTE

### MPQ1000 Common Connections

#### 3 Wire Single Phase Residential Meter

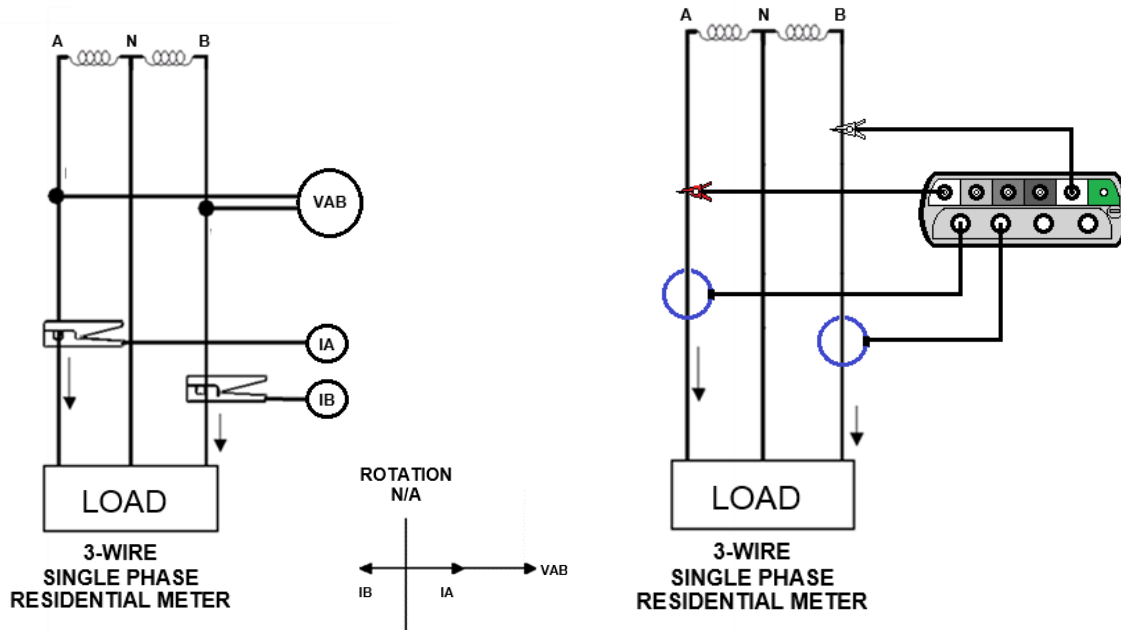

#### 1.5 Wattmeter – (1 Voltage and 2 Current)

When connected the phase rotation of the phase A current must be within +/- 90 degrees of the voltage.

The phase rotation of the phase B current must be greater than +/- 90 degrees of the voltage.

The phase A current arrow will need to be within the yellow range and the phase B current will need to be in the green range as shown in the image.

If the phase rotation does not match then this will indicate that either the CT or the voltage connections are backwards.

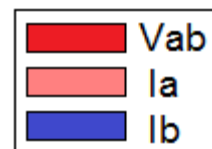
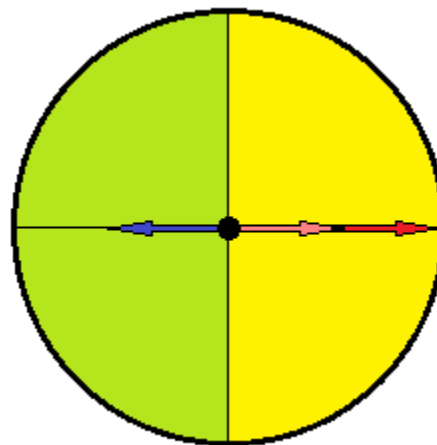

# APPLICATION NOTE

## MPQ1000 Common Connections

### Megger PQ PC Software configuration

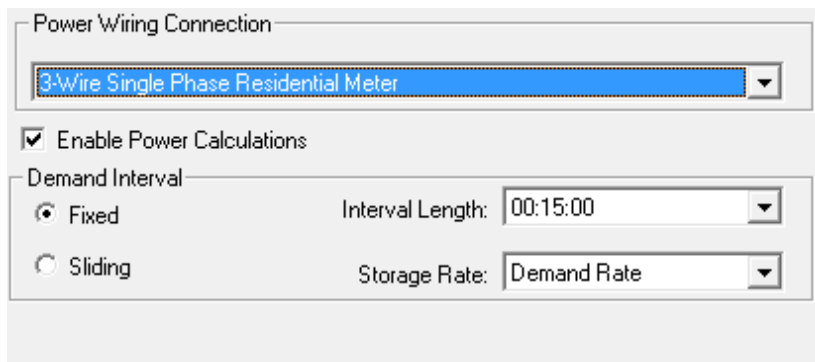

Megger PQ PC software “3 Wire Single Residential” configuration needs to be used with this type of connection.

Label	Channel	Sag Limit	Swell Limit	SubCycle Limit	Ratio	CT Full Scale	Nom Angle	Angle Dev +/-	RVC Thresh (%)	RVC Hysteresis (%)	Fast Transient (Volts)	THD Limit %
<input checked="" type="checkbox"/> Vab	V1	<input type="checkbox"/> 228.000	<input type="checkbox"/> 252.000	240.0	1.000		0.00		3.00	10.00	<input type="checkbox"/> 252.000	<input type="checkbox"/> 7.00000
<input checked="" type="checkbox"/> Ia	I1	<input type="checkbox"/> 0.00000	<input type="checkbox"/> 300.000	300.0	1.000	6000.00						<input type="checkbox"/> 20.0000
<input type="checkbox"/>	V2	<input type="checkbox"/> 228.000	<input type="checkbox"/> 252.000	240.0	1.000		180.00	2.00	3.00	10.00	<input type="checkbox"/> 252.000	<input type="checkbox"/> 7.00000
<input checked="" type="checkbox"/> Ib	I2	<input type="checkbox"/> 0.00000	<input type="checkbox"/> 300.000	300.0	1.000	6000.00						<input type="checkbox"/> 20.0000
<input type="checkbox"/> Vc	V3	<input type="checkbox"/> 228.000	<input type="checkbox"/> 252.000	240.0	1.000				3.00	10.00	<input type="checkbox"/> 252.000	<input type="checkbox"/> 7.00000
<input type="checkbox"/> Ic	I3	<input type="checkbox"/> 0.00000	<input type="checkbox"/> 300.000	300.0	1.000	6000.00						<input type="checkbox"/> 20.0000
<input type="checkbox"/> Vn	V4	<input type="checkbox"/> 228.000	<input type="checkbox"/> 5.00000	12.00	1.000				3.00	10.00		<input type="checkbox"/> 7.00000
<input type="checkbox"/> In	I4	<input type="checkbox"/> 0.00000	<input type="checkbox"/> 300.000	300.0	1.000	6000.00						<input type="checkbox"/> 20.0000

This configuration will automatically enable channel V1 “Vab”, channel I1 “Ia” and channel I2 “Ib” since these channels are required for the power calculation.

Other channels can be enabled and connected to different nodes. This will not affect the power measurements.

Channel labels in the “Label” column can be changed to meet user needs. Up to 4 characters can be used.

The 3 Wire Single Phase Residential Meter configuration utilized phase voltage (Phase – Phase) and line current. When demand data (Power and Energy) is recorded only total power data will be valid and available.

## APPLICATION NOTE

### MPQ1000 Common Connections

#### 3 Wire Delta 2 Wattmeter

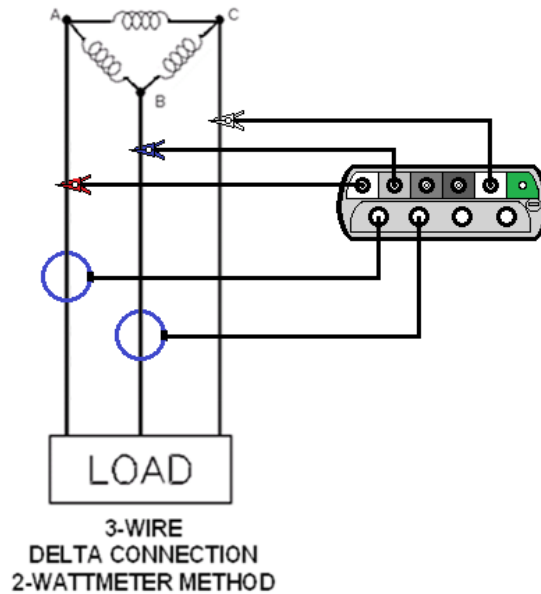
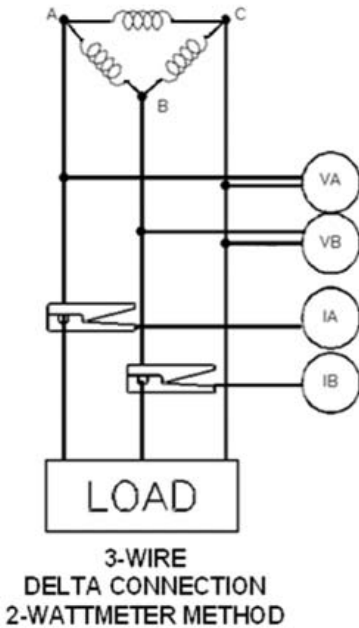

2 Wattmeter – (2 Voltage and 2 Current)

In a 3 wire delta 2 wattmeter configuration there can be 2 possible phase rotation, depending on how the analyzer is connected.

There can be an AC-CB-BA rotation as shown in figure 1.

There can be an AC-BA-CB rotation as shown in figure 2.

In either case the currents will have a 30 degree shift from the voltage. This is because the voltage measurement is a phase to phase measurement and the current measurement is a line current measurement.

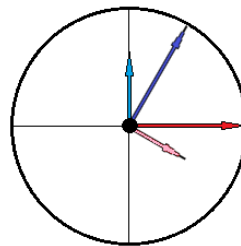

Figure 1

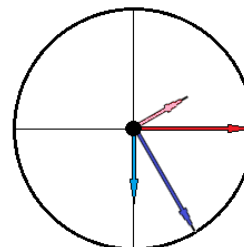
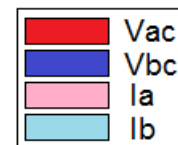

Figure 2

## APPLICATION NOTE

### MPQ1000 Common Connections

Due to the natural 30° shift due to a phase to phase voltage and line current the phase rotation of the currents must be within +/- 90 degrees of the voltage plus the 30 degrees shift.

In an AC-CB-BA rotation the phase A current arrow will need to be within the yellow range and the phase B current will need to be in the green range, as shown in figure 1.

In an AC-BA-CB rotation the phase A current arrow will need to be within the yellow range and the phase B current will need to be in the green range, as shown in figure 2.

If the phase rotation does not match then this will indicate that either the CT or the voltage connections are backwards.

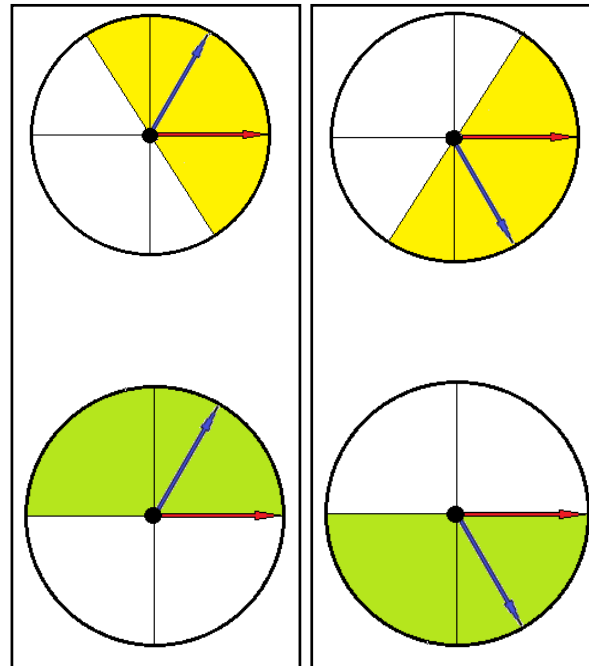

Figure 1

Figure 2



### Megger PQ PC Software configuration

Power Wiring Connection

3-Wire Delta 2-Wattmeter

Enable Power Calculations

Demand Interval

Fixed Interval Length: 00:15:00

Sliding Storage Rate: Demand Rate

Megger PQ PC software “3 Wire Delta 2-Wattmeter” configuration needs to be used with this type of connection.

# APPLICATION NOTE

## MPQ1000 Common Connections

Label	Channel	Sag Limit	Swell Limit	SubCycle Limit	Ratio	CT Full Scale	Nom Angle	Angle Dev +/-	RVC Thresh (%)	RVC Hysteresis (%)	Fast Transient (Volts)	THD Limit %
<input checked="" type="checkbox"/> Vac	V1	<input type="checkbox"/> 198.000	<input type="checkbox"/> 218.000	208.0	1.000		0.00		3.00	10.00	<input type="checkbox"/> 218.000	<input type="checkbox"/> 7.00000
<input checked="" type="checkbox"/> Ia	I1	<input type="checkbox"/> 0.00000	<input type="checkbox"/> 6000.00	600.0	1.000	6000.00						<input type="checkbox"/> 20.00000
<input checked="" type="checkbox"/> Vbc	V2	<input type="checkbox"/> 198.000	<input type="checkbox"/> 218.000	208.0	1.000		60.00	2.00	3.00	10.00	<input type="checkbox"/> 218.000	<input type="checkbox"/> 7.00000
<input checked="" type="checkbox"/> Ib	I2	<input type="checkbox"/> 0.00000	<input type="checkbox"/> 6000.00	600.0	1.000	6000.00						<input type="checkbox"/> 20.00000
<input type="checkbox"/> Vab	V3	<input type="checkbox"/> 198.000	<input type="checkbox"/> 218.000	208.0	1.000				3.00	10.00	<input type="checkbox"/> 218.000	<input type="checkbox"/> 7.00000
<input type="checkbox"/> Ic	I3	<input type="checkbox"/> 0.00000	<input type="checkbox"/> 6000.00	600.0	1.000	6000.00						<input type="checkbox"/> 20.00000
<input type="checkbox"/> Vn	V4	<input type="checkbox"/> 198.000	<input type="checkbox"/> 5.00000	12.00	1.000				3.00	10.00		<input type="checkbox"/> 7.00000
<input type="checkbox"/> In	I4	<input type="checkbox"/> 0.00000	<input type="checkbox"/> 6000.00	600.0	1.000	6000.00						<input type="checkbox"/> 20.00000

This configuration will automatically enable channel V1 “Vac”, channel V2 “Vbc”, channel I1 “Ia” and channel I2 “Ib” since these channels are required for the power calculation.

Other channels can be enabled and connected to different nodes. This will not affect the power measurements.

NOTE: V3 “Vab” is NOT connected. The analyzer will automatically calculate the Phase C voltage and display the value on the DMM screen. The value will also be calculated in the Megger PC software.

For I3 “Ic” current to be recorded this channel needs to be enabled and a CT connected. Channel labels in the “Label” column can be changed to meet user needs. Up to 4 characters can be used.

The 3 Wire Delta 2 Wattmeter configuration utilized phase voltage (Phase – Phase) and line current. When demand data (Power and Energy) is recorded only total power data will be valid and available.

## APPLICATION NOTE

### MPQ1000 Common Connections

#### 3 Wire Split Phase 2 Wattmeter

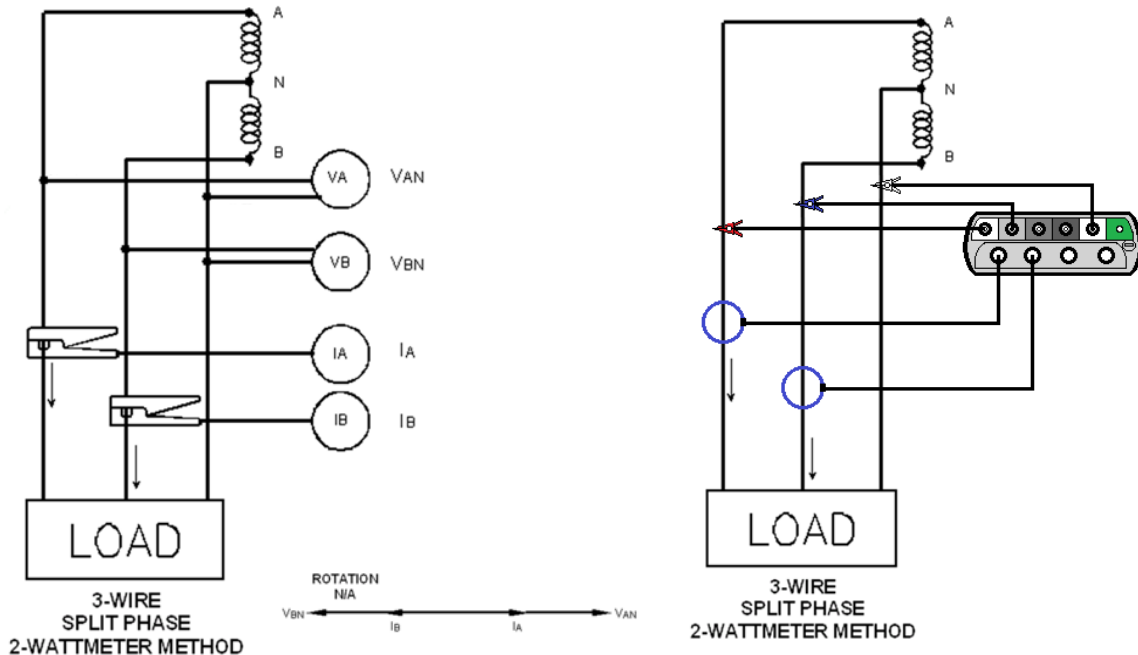

2 Wattmeter – (2 Voltage and 2 Current)

When connected the phase rotation of the phase A current must be within +/- 90 degrees of the phase A voltage and the phase rotation of the phase B current must be within +/- 90 degrees of the Phase B voltage.

The phase A current arrow will need to be within the yellow range and the phase B current will need to be in the green range as shown in the image.

If the phase rotation does not match then this will indicate that either the CT or the voltage connections are backwards.

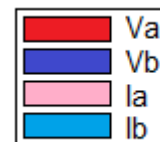
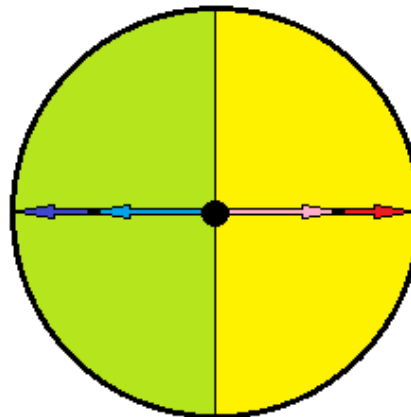

Line Voltage (Phase – Neutral)  
Line Current



# APPLICATION NOTE

## MPQ1000 Common Connections

Megger PQ PC Software configuration

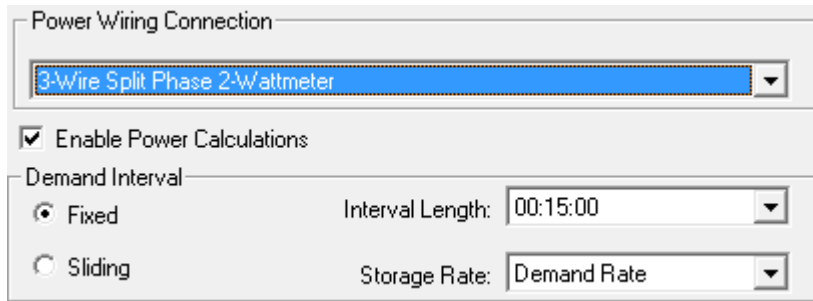

Power Wiring Connection

3-Wire Split Phase 2-Wattmeter

Enable Power Calculations

Demand Interval

Fixed Interval Length: 00:15:00

Sliding Storage Rate: Demand Rate

Megger PQ PC software “3 Wire Split Phase 2-Wattmeter” configuration needs to be used with this type of connection.

Label	Channel	Sag Limit	Swell Limit	SubCycle Limit	Ratio	CT Full Scale	Nom Angle	Angle Dev +/-	RVC Thresh (%)	RVC Hysteresis (%)	Fast Transient (Volts)	THD Limit %
<input checked="" type="checkbox"/> Va	V1	<input type="checkbox"/> 114.000	<input type="checkbox"/> 126.000	120.0	1.000		0.00		3.00	10.00	<input type="checkbox"/> 126.000	<input type="checkbox"/> 7.00000
<input checked="" type="checkbox"/> Ia	I1	<input type="checkbox"/> 0.00000	<input type="checkbox"/> 300.000	300.0	1.000	6000.00						<input type="checkbox"/> 20.00000
<input checked="" type="checkbox"/> Vb	V2	<input type="checkbox"/> 114.000	<input type="checkbox"/> 126.000	120.0	1.000		180.00	2.00	3.00	10.00	<input type="checkbox"/> 126.000	<input type="checkbox"/> 7.00000
<input checked="" type="checkbox"/> Ib	I2	<input type="checkbox"/> 0.00000	<input type="checkbox"/> 300.000	300.0	1.000	6000.00						<input type="checkbox"/> 20.00000
<input type="checkbox"/> Vc	V3	<input type="checkbox"/> 114.000	<input type="checkbox"/> 126.000	120.0	1.000				3.00	10.00	<input type="checkbox"/> 126.000	<input type="checkbox"/> 7.00000
<input type="checkbox"/> Ic	I3	<input type="checkbox"/> 0.00000	<input type="checkbox"/> 300.000	300.0	1.000	6000.00						<input type="checkbox"/> 20.00000
<input type="checkbox"/> Vn	V4	<input type="checkbox"/> 114.000	<input type="checkbox"/> 5.00000	12.00	1.000				3.00	10.00		<input type="checkbox"/> 7.00000
<input type="checkbox"/> In	I4	<input type="checkbox"/> 0.00000	<input type="checkbox"/> 300.000	300.0	1.000	6000.00						<input type="checkbox"/> 20.00000

This configuration will automatically enable channel V1 “Va”, channel V2 “Vb”, channel I1 “Ia” and channel I2 “Ib” since these channels are required for the power calculation.

Other channels can be enabled and connected to different nodes. This will not affect the power measurements.

Channel labels in the “Label” column can be changed to meet user needs. Up to 4 characters can be used.

The 3 Wire Split 2 Wattmeter configuration utilized line voltage (Phase – Neutral) and line current. When demand data (Power and Energy) is recorded both phase power and total power data will be valid and available.

## APPLICATION NOTE

### MPQ1000 Common Connections

#### 3 Wire Wye 2 Wattmeter

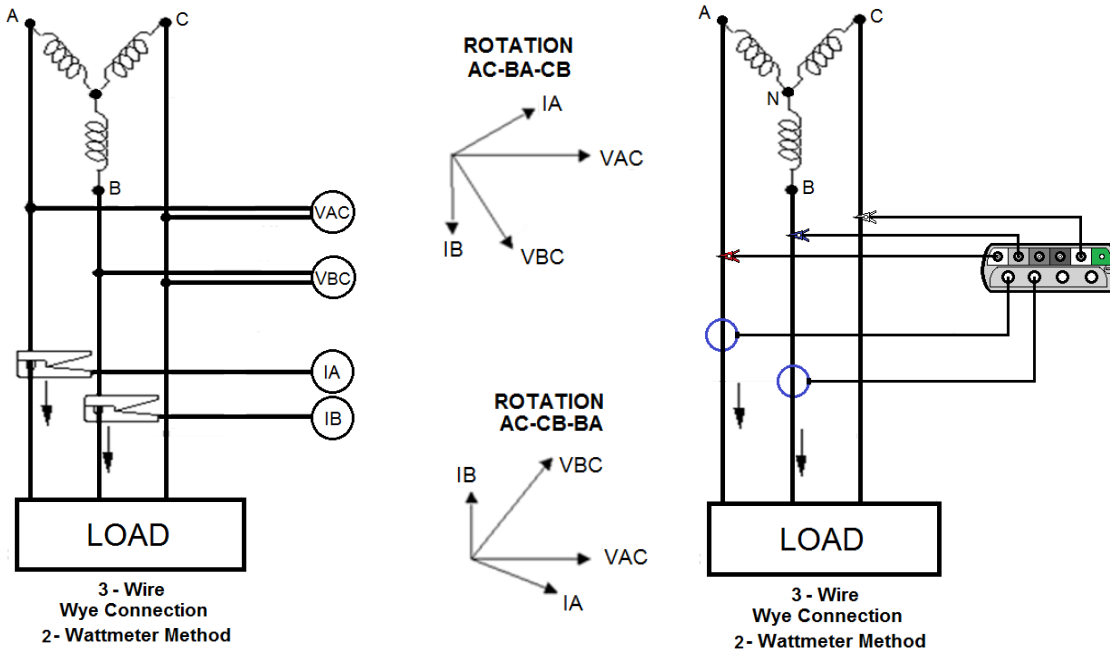

#### 2 Wattmeter – (2 Voltage and 2 Current)

In a 3 wire WYE 2 wattmeter configuration there can be 2 possible phase rotation, depending on how the analyzer is connected.

There can be an AC-CB-BA rotation as shown in figure 1.

There can be an AC-BA-CB rotation as shown in figure 2.

In either case the currents will have a 30 degree shift from the voltage. This is because the voltage measurement is a phase to phase measurement and the current measurement is a line current measurement.

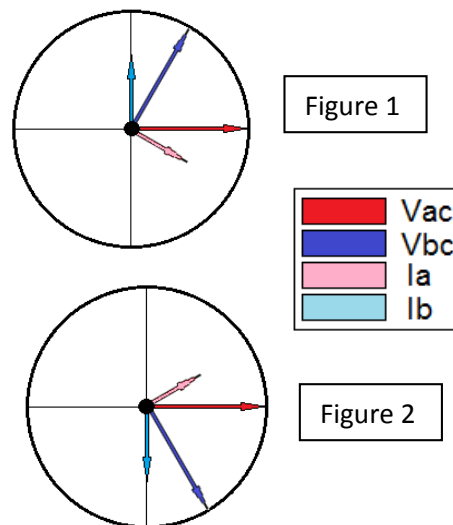

## APPLICATION NOTE

### MPQ1000 Common Connections

Due to the natural 30° shift due to a phase to phase voltage and line current the phase rotation of the currents must be within +/- 90 degrees of the voltage plus the 30 degrees shift.

In an AC-CB-BA rotation the phase A current arrow will need to be within the yellow range and the phase B current will need to be in the green range, as shown in figure 1.

In an AC-BA-CB rotation the phase A current arrow will need to be within the yellow range and the phase B current will need to be in the green range, as shown in figure 2.

If the phase rotation does not match then this will indicate that either the CT or the voltage connections are backwards.

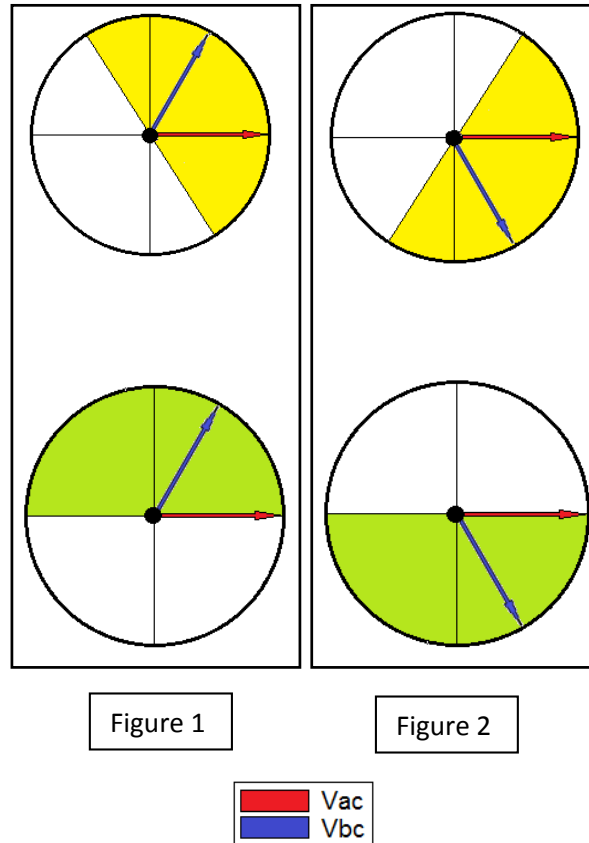

#### Megger PQ PC Software configuration

Power Wiring Connection

3-Wire Wye 2-Wattmeter

Enable Power Calculations

Demand Interval

Fixed      Interval Length: 00:15:00

Sliding      Storage Rate: Demand Rate

Megger PQ PC software “3 Wire Wye 2-Wattmeter” configuration needs to be used with this type of connection.

# APPLICATION NOTE

## MPQ1000 Common Connections

Label	Channel	Sag Limit	Swell Limit	SubCycle Limit	Ratio	CT Full Scale	Nom Angle	Angle Dev +/-	RVC Thresh (%)	RVC Hysteresis (%)	Fast Transient (Volts)	THD Limit %
<input checked="" type="checkbox"/> Vac	V1	<input type="checkbox"/> 198.000	<input type="checkbox"/> 218.000	208.0	1.000		0.00		3.00	10.00	<input type="checkbox"/> 218.000	<input type="checkbox"/> 7.00000
<input checked="" type="checkbox"/> Ia	I1	<input type="checkbox"/> 0.00000	<input type="checkbox"/> 300.000	300.0	1.000	6000.00						<input type="checkbox"/> 20.00000
<input checked="" type="checkbox"/> Vbc	V2	<input type="checkbox"/> 198.000	<input type="checkbox"/> 218.000	208.0	1.000		60.00	2.00	3.00	10.00	<input type="checkbox"/> 218.000	<input type="checkbox"/> 7.00000
<input checked="" type="checkbox"/> Ib	I2	<input type="checkbox"/> 0.00000	<input type="checkbox"/> 300.000	300.0	1.000	6000.00						<input type="checkbox"/> 20.00000
<input type="checkbox"/> Vab	V3	<input type="checkbox"/> 198.000	<input type="checkbox"/> 218.000	208.0	1.000				3.00	10.00	<input type="checkbox"/> 218.000	<input type="checkbox"/> 7.00000
<input type="checkbox"/> Ic	I3	<input type="checkbox"/> 0.00000	<input type="checkbox"/> 300.000	300.0	1.000	6000.00						<input type="checkbox"/> 20.00000
<input type="checkbox"/> Vn	V4	<input type="checkbox"/> 198.000	<input type="checkbox"/> 5.00000	12.00	1.000				3.00	10.00		<input type="checkbox"/> 7.00000
<input type="checkbox"/> In	I4	<input type="checkbox"/> 0.00000	<input type="checkbox"/> 300.000	300.0	1.000	6000.00						<input type="checkbox"/> 20.00000

This configuration will automatically enable channel V1 “Vac”, channel V2 “Vbc”, channel I1 “Ia” and channel I2 “Ib” since these channels are required for the power calculation.

Other channels can be enabled and connected to different nodes. This will not affect the power measurements.

NOTE: V3 “Vab” is NOT connected. The analyzer will automatically calculate the Phase C voltage and display the value on the DMM screen. The value will also be calculated in the Megger PC software.

For I3 “Ic” current to be recorded this channel needs to be enabled and a CT connected. Channel labels in the “Label” column can be changed to meet user needs. Up to 4 characters can be used.

The 3 Wire Wye 2 Wattmeter configuration utilized phase voltage (Phase – Phase) and line current. When demand data (Power and Energy) is recorded only total power data will be valid and available.

## APPLICATION NOTE

### MPQ1000 Common Connections

#### 4 Wire Wye 3 Wattmeter

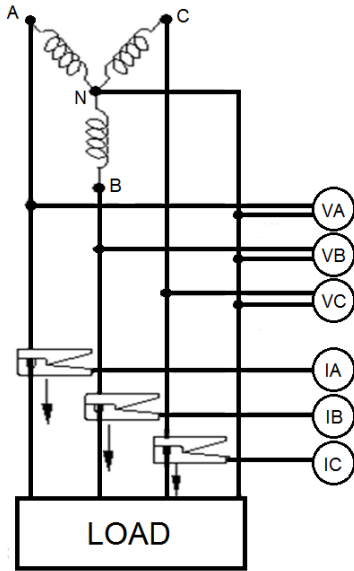

4 - Wire  
Wye Connection  
3 - Wattmeter Method

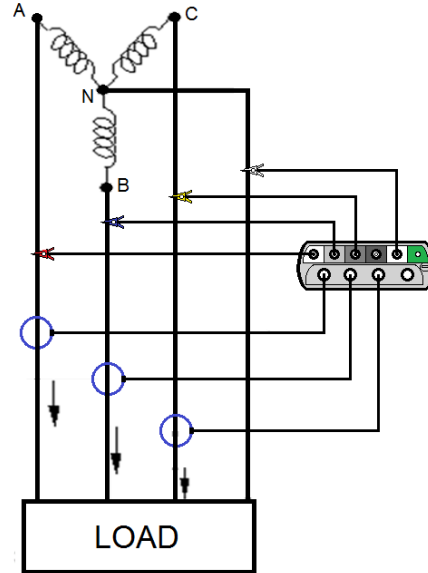
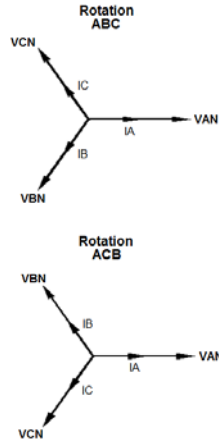

4 - Wire  
Wye Connection  
3 - Wattmeter Method

#### 3 Wattmeter – (3 Voltage and 3 Current)

The phase angles of the 4 wire wye 3 wattmeter configuration can be either an ABC rotation or a ACB rotation.

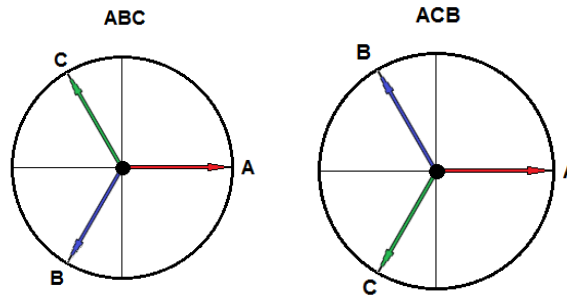

## APPLICATION NOTE

### MPQ1000 Common Connections

When connected the phase rotation of the current must be within +/- 90 degrees of their respective voltage angles.

In a ACB rotation the Phase A current angle must fall in the zone shown in yellow. The Phase B current angle must fall in the zone shown in green. The Phase C current angle must fall in the zone shown in blue.

If the phase rotation of any of the current angles exceed 90 degrees of their voltage angle then this will indicate that either the CT or the voltage connections are backwards.

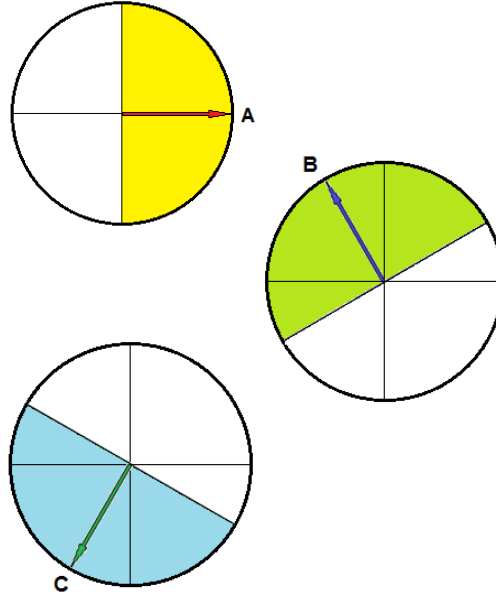

### Megger PQ PC Software configuration

Power Wiring Connection

4-Wire Wye 3-Wattmeter

Enable Power Calculations

Demand Interval

Fixed Interval Length: 00:15:00

Sliding Storage Rate: Demand Rate

Megger PQ PC software “4 Wire Wye 3 Wattmeter” configuration needs to be used with this type of connection.

Label	Channel	Sag Limit	Swell Limit	SubCycle Limit	Ratio	CT Full Scale	Nom Angle	Angle Dev +/-	RVC Thresh (%)	RVC Hysteresis (%)	Fast Transient (Volts)	THD Limit %
<input checked="" type="checkbox"/> Va	V1	<input type="checkbox"/> 114.000	<input type="checkbox"/> 126.000	120.0	1.000		0.00		3.00	10.00	<input type="checkbox"/> 126.000	<input type="checkbox"/> 7.00000
<input checked="" type="checkbox"/> Ia	I1	<input type="checkbox"/> 0.00000	<input type="checkbox"/> 6000.00	600.0	1.000	6000.00						<input type="checkbox"/> 20.0000
<input checked="" type="checkbox"/> Vb	V2	<input type="checkbox"/> 114.000	<input type="checkbox"/> 126.000	120.0	1.000		120.00	2.00	3.00	10.00	<input type="checkbox"/> 126.000	<input type="checkbox"/> 7.00000
<input checked="" type="checkbox"/> Ib	I2	<input type="checkbox"/> 0.00000	<input type="checkbox"/> 6000.00	600.0	1.000	6000.00						<input type="checkbox"/> 20.0000
<input checked="" type="checkbox"/> Vc	V3	<input type="checkbox"/> 114.000	<input type="checkbox"/> 126.000	120.0	1.000		240.00	2.00	3.00	10.00	<input type="checkbox"/> 126.000	<input type="checkbox"/> 7.00000
<input checked="" type="checkbox"/> Ic	I3	<input type="checkbox"/> 0.00000	<input type="checkbox"/> 6000.00	600.0	1.000	6000.00						<input type="checkbox"/> 20.0000
<input type="checkbox"/> Vn	V4	<input type="checkbox"/> 114.000	<input type="checkbox"/> 5.00000	12.00	1.000				3.00	10.00		<input type="checkbox"/> 7.00000
<input type="checkbox"/> In	I4	<input type="checkbox"/> 0.00000	<input type="checkbox"/> 6000.00	600.0	1.000	6000.00						<input type="checkbox"/> 20.0000

This configuration will automatically enable channel V1 “Va”, channel V2 “Vb”, channel V3 “Vc”, channel I1 “Ia”, channel I2 “Ib” and channel I3 “Ic”, since these channels are required for the power calculation.

Other channels can be enabled and connected to different nodes. This will not affect the power measurements. Channel labels in the “Label” column can be changed to meet user needs. Up to 4 characters can be used.