



# Reducing failure risk of HV instrument transformers in the transmission system

**Megger**<sup>®</sup>

**CASE STUDY**  
NB DFR on HV CVTs

# Reducing failure risk of HV instrument transformers in the transmission system

## – application of narrowband dielectric frequency response (NB DFR) on HV CVTs

### Background

- The utility's SCADA system indicated a loss of voltage in one phase.
- Because 765kV CVTs provide the voltage information to all control, metering and protection systems at this location, the CVT (CVT-1) corresponding to that specific phase was immediately suspect.

### Summary:

- 10 kV capacitance and power factor (PF) tests at line frequency (Figure 1) confirmed insulation failure of C1 sections B2 and B3 of CVT-1 (Figure 2).

INSULATION TESTED	TEST MODE	TEST KV	Test Freq	L(H) CAP.(pF)	POWER FACTOR %			Equivalent @ 10 kV		%VDF
					MEAS	@ 20°C	CORR.	mA	Watts	
B1-C1	GST-GND	10.00	60	29,776.85 pF	0.16			112.2635	1.8343	0.06
108-B3-C1-9117	GST-GND	10.00	60	18,205.73 pF	5.46			68.7714	37.8119	19.76
101-B2-C1-25721	GST-GND	10.00	60	44,625.85 pF	4.49			168.4252	75.6787	0.62
104-B4-C1-9120	GST-GND	10.00	60	25,942.91 pF	0.17			97.7748	1.6199	0.06

Figure 1: Megger Delta Control results of CVT-1's C1 sections B1 to B4

(Note elevated % PF results, significant discrepancies in capacitance between sections, and high, non-zero % VDFs, which indicate PF voltage dependencies, in sections B2 and B3).

- For additional insights, 250 V narrowband dielectric frequency response (NB DFR) tests, comprised of PF measurements made between 1 and 500 Hz, were performed on all 4 sections of CVT-1 (Figure 3).
- The customer reported this fairly obvious failure as an over-pressure event and replaced CVT-1 with CVT-1R.
- CVT-1R was similarly tested. Its acceptable capacitance and PF and NB DFR test results (Figures 4 and 5) serve as helpful, normative references for CVT test results.

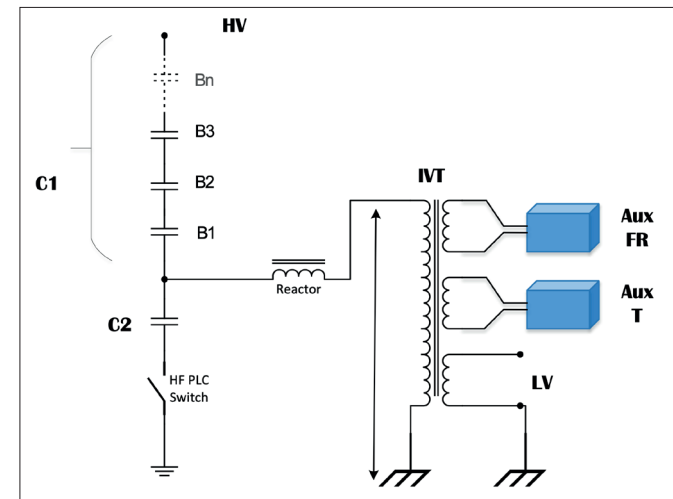

Figure 2: CVT simplified scheme

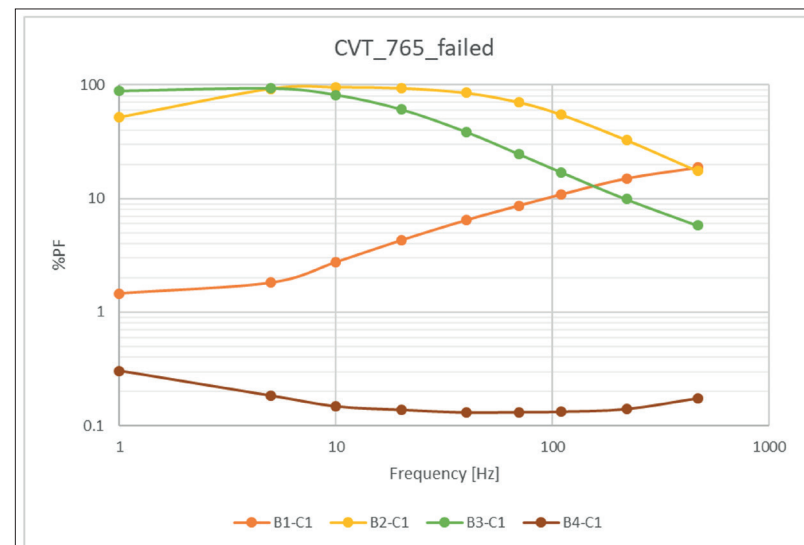

Figure 3: NB DFR plot of failed CVT 1's C1 sections B1 to B4

(Note the % PF at 60 Hz in the 250 V NB DFR test results above; comparing to the 10 kV % PF test results in Figure 1 confirms significant, abnormal voltage dependencies.)

INSULATION TESTED	TEST MODE	SUPPRESS.	TEST kV	Test Freq	L(H) CAP. (pF)		POWER FACTOR %			Equivalent @ 10 kV		%VDF
							MEAS.	@ 20°C	CORR.	mA	Watts	
B1-26502	GST-GND	Freq Variation	10.00	60	30,436.84	pF	0.08			114.7414	0.9714	0.05
C2-220469	GST-GND	Freq Variation	2.00	60	22,197.3	pF	0.11			836.5971	8.9591	0.05
108-B3-C1-26436	GST-GND	Freq Variation	10.00	60	26,710.64	pF	0.08			100.6802	0.8329	0.05
101-B2-C1-26524	GST-GND	Freq Variation	10.00	60	26,801.90	pF	0.08			101.0157	0.8430	0.04
104-B4-C1-26621	GST-GND	Freq Variation	10.00	60	26,903.76	pF	0.10			101.4393	0.9664	0.04

Figure 4: Acceptable capacitance and PF test results for replacement CVT-1R  
(Note that a ratio test performed at 10 kV and a digital multimeter indicated acceptable ratio results.)

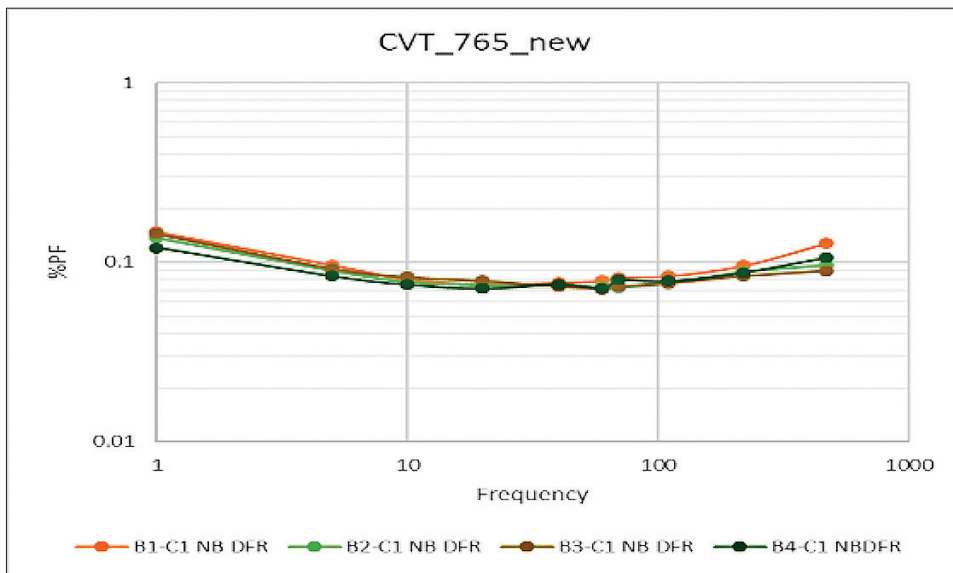

Figure 5: Acceptable NB DFR test results for replacement CVT-1R C1 sections B1 – B4

While replacing CVT-1, the testing specialist noticed a stain on the surface of the adjacent phase CVT (CVT-2, Figure 6). CVT-2 was reporting an expected voltage in SCADA but given the failure of CVT-1 and convenient access to the testing equipment, capacitance and PF tests and NB DFR tests were performed on CVT-2 (Figures 7 – 10). Testing revealed insulation failure of CVT-2.

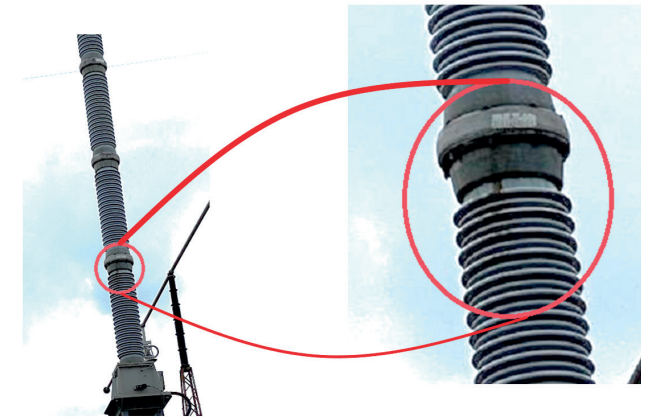

Figure 6: CVT-2 as found during visual inspection

(Note that a ratio test performed at 10 kV and a digital multimeter indicated acceptable ratio results.)

# Reducing failure risk of HV instrument transformers in the transmission system

## – application of narrowband dielectric frequency response (NB DFR) on HV CVTs

TEST NO	INSULATION TESTED	TEST KV	Test Freq	L(H) CAP.(pF)	POWER FACTOR %			Equivalent @ 10 kV		%VDF
					MEAS.	@ 20°C	CORR.	mA	Watts	
1	B1 C1 cal 28963 +1.88%	10.00	60	29,509.65 pF	0.25			111.2432	2.7362	0.06

Figure 7: C1-B1 section capacitance and PF test results for stained CVT-2

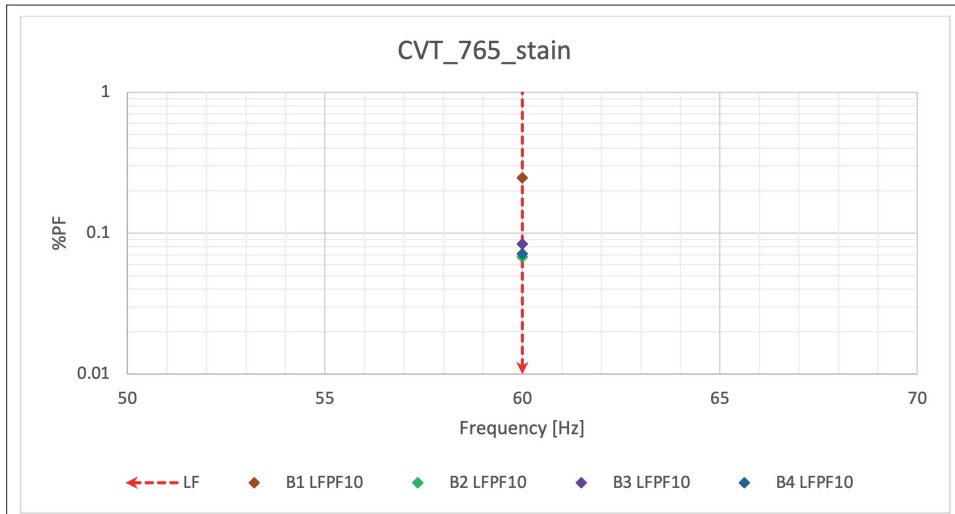

Figure 8: 10kV line frequency % PF test results for C1 sections B1 – B4 of CVT-2  
(Note the elevated % PF for C1-B1 section (0.25%) relative to the other 3 sections (~0.08%.)

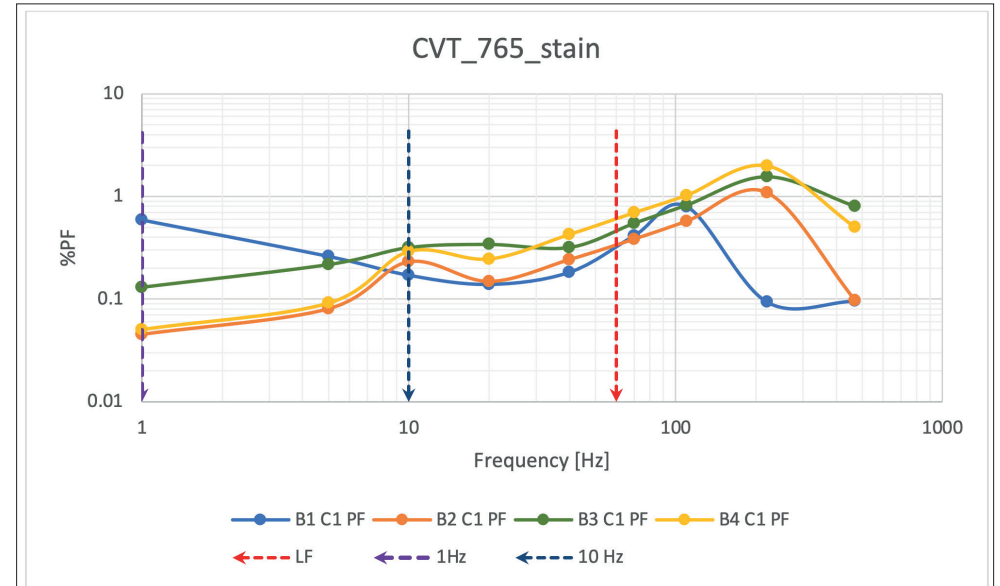

Figure 9: NB DFR test results 1-500Hz on CVT-2  
(Note that all units connected in series have been affected and the dielectric response presents an atypical response for all 4 sections. The 1Hz test result of C1 section B1 revealed a different behavior compared to the other sections and a PF tip-up test, Figure 10, was performed to verify its voltage dependence.)

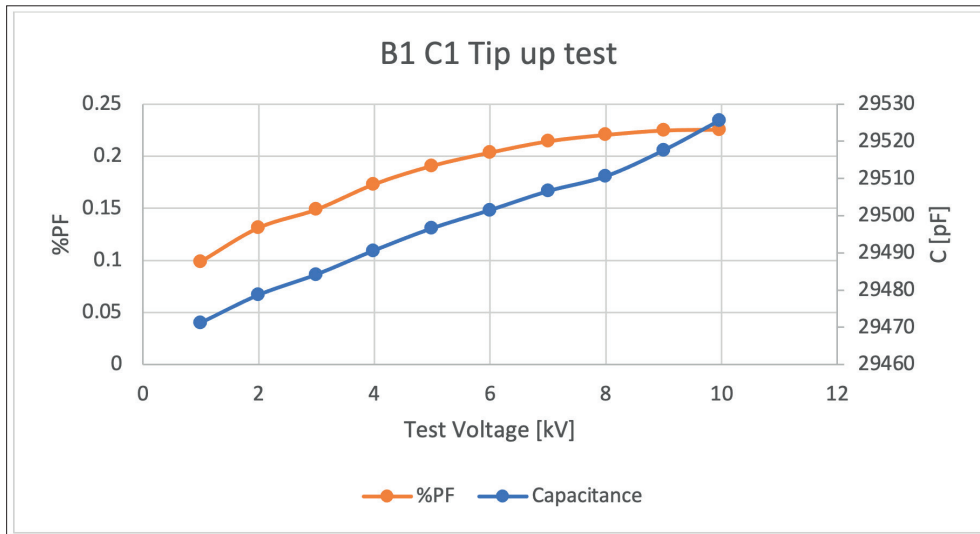

Figure 10: Power factor tip-up test results for C1-B1 section of CVT-2



Figure 11: Oil overflow due to puncture on top of C1-B1 section

■ An ensuing teardown of CVT-2 confirmed significant damage to its C1 – B1 section (Figure 11.). Specifically:

- A puncture was found in the C1-B1 section
- Oil was missing from the top portion of C1-B1 section.
- Its insulation integrity was compromised
- Ratio was not affected
- CVT-2 was also replaced.

### Takeaways:

- A CVT in good condition should have a very low % PF value (at 20°C) <0.2% at 1Hz (Figure 5).
- The utility performs monthly visual inspections but did not notice the oil leak between C1 sections of CVT-2. Testing averted its likely failure.
- NB DFR testing will be incorporated in the utility’s future routine maintenance of CVTs.
- The Megger Delta 4000 and TDX120 provide both basic (capacitance and PF) and advanced (NB DFR) diagnostic insulation testing. Atypical NB DFR results should be further investigated with a full dielectric frequency response (DFR) test using the Megger IDAX 300.

# Reducing failure risk of HV instrument transformers in the transmission system

– application of narrowband dielectric frequency response (NB DFR) on HV CVTs

## Product Reference:



### DELTA:

- Dedicated capacitance and PF/DF test instrument (also exciting current)
- Narrowband DFR (NB DFR: 1 - 500 Hz)
- Individual Temperature Correction (ITC)
- Voltage Dependence Detection (VDD)



### TRAX + TDX

- A multi-functional tester for transformer and substation equipment
- Narrowband DFR (NB DFR: 1 - 500 Hz)
- Individual Temperature Correction (ITC)
- Voltage Dependence Detection (VDD)



### IDAX + VAX

- Megger's DFR test instrument – analysis of moisture content, PF/DF and oil conductivity
- Fast and reliable in high-interference environments (up to 1.4 kVrms test voltage)
- The result of 20+ years of experience in the design and application of DFR test instruments
- Can also perform transformer dry-out monitoring



**For additional information contact:**

- **Vince Oppedisano**  
Power Transformer Product Specialist  
vince.oppedisano@megger.com
  
- **Kenneth Petroff**  
Product Manager Power Transformer  
kenneth.petroff@megger.com
  
- **Dr. Diego Robalino**  
Business Development Director  
Transformer Segment  
diego.robalino@megger.com

Megger Limited  
Archcliffe Road  
Dover CT17 9EN  
United Kingdom

[www.megger.com](http://www.megger.com)

765kV\_CVT\_CaseStudy\_V03

The word 'Megger' is a registered trademark. Copyright © 2021

